



US007377667B2

(12) **United States Patent**
Richmond

(10) **Patent No.:** **US 7,377,667 B2**

(45) **Date of Patent:** **May 27, 2008**

(54) **LIGHT DEVICE**

(76) Inventor: **Simon Nicholas Richmond**, 47
Grasmere Rd., Princeton, NJ (US)
08540

5,183,324 A 2/1993 Thomas
5,819,917 A 10/1998 Nicholson
6,511,197 B1 1/2003 Kalemjian
7,011,426 B2 3/2006 Gabor
7,040,776 B2 5/2006 Harrell et al.
7,048,403 B2 5/2006 Parker et al.

(*) Notice: Subject to any disclaimer, the term of this patent is extended or adjusted under 35 U.S.C. 154(b) by 80 days.

(21) Appl. No.: **11/279,729**

Primary Examiner—Thomas M Sember
(74) *Attorney, Agent, or Firm*—Davis Wright Tremaine LLP; George C. Rondeau, Jr.

(22) Filed: **Apr. 13, 2006**

(57) **ABSTRACT**

(65) **Prior Publication Data**

US 2006/0279956 A1 Dec. 14, 2006

Related U.S. Application Data

(63) Continuation-in-part of application No. 11/057,077, filed on Feb. 11, 2005, now abandoned.

A light device (10, 30) is described which comprises a first portion (12) configured so as to partially define a housing, the first portion (12) being arranged so as to at least partially pass light therethrough and the first portion (12) including first electrical contacts (46, 48) and a first locking device (50), a light emitting element (15) disposed in the first portion (12) and being electrically connected to the first electrical contacts (46, 48) and a second portion including a battery compartment (56), second electrical contacts (52, 54) arranged so as to be in electrical connection with batteries disposed in the battery compartment during use, and a second locking device (62, 64) engageable with the first locking device (50) so as to releasibly fix the second portion (13) to the first portion (12) during use and thereby close the housing. The arrangement is such that, during use, when the first and second locking devices (50, 62, 64) are engaged with each other, the first electrical contacts (50) electrically connect with the second electrical contacts (62, 64) so as to thereby electrically connect batteries disposed in the battery compartment (56) during use to the at least one light emitting element (15).

(30) **Foreign Application Priority Data**

Feb. 13, 2004 (AU) 2004900700

(51) **Int. Cl.**
F21V 33/00 (2006.01)

(52) **U.S. Cl.** **362/155**; 362/183; 362/392;
362/649; 362/810

(58) **Field of Classification Search** 362/810,
362/392, 374, 375, 645, 647, 649, 650, 651,
362/154, 155, 295, 156, 183; 206/216, 418,
206/566

See application file for complete search history.

(56) **References Cited**

U.S. PATENT DOCUMENTS

4,974,130 A 11/1990 Friedman

8 Claims, 18 Drawing Sheets

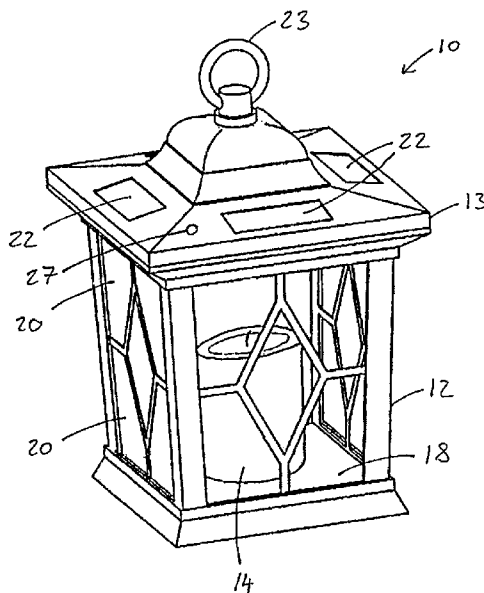

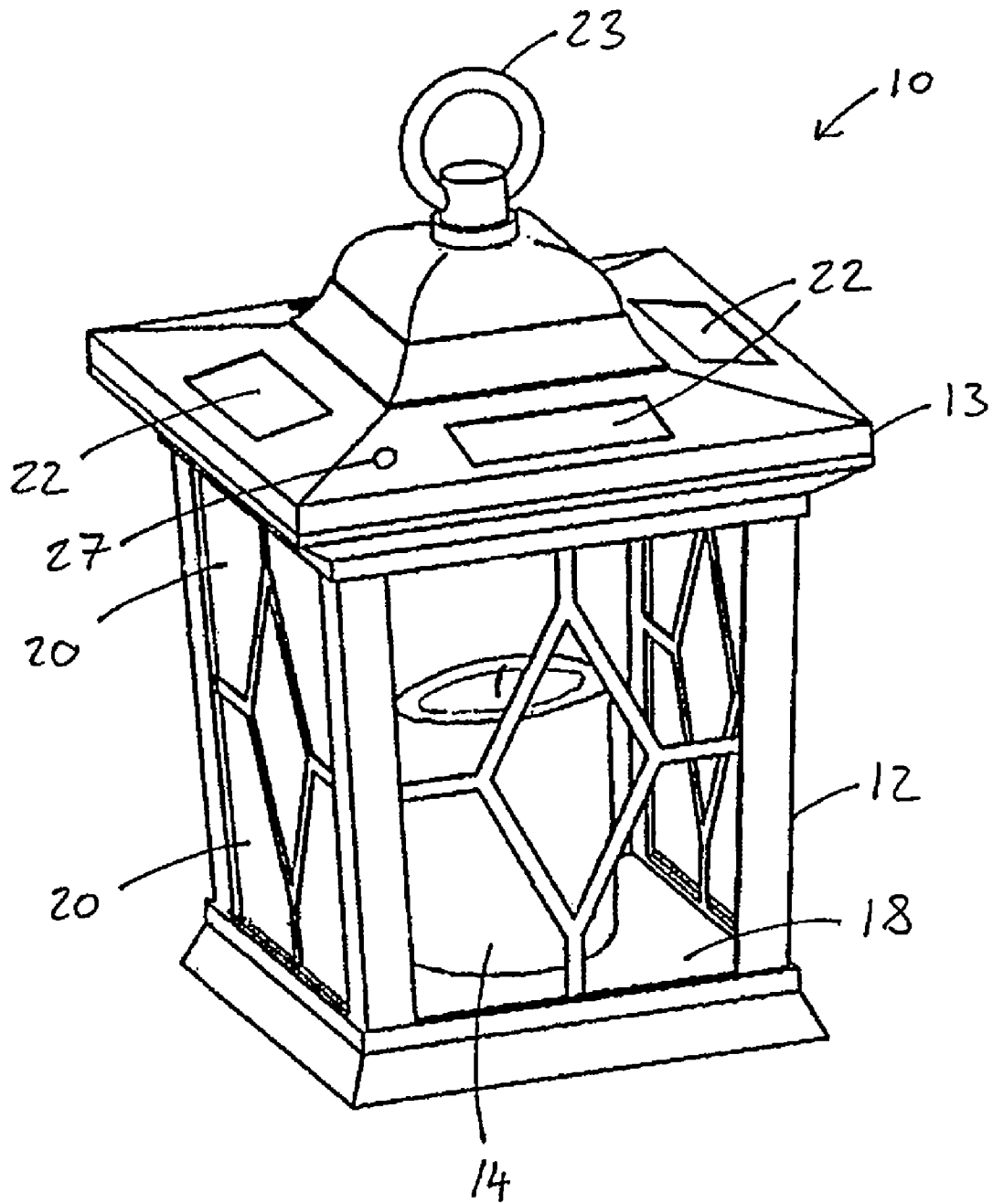

Fig. 1

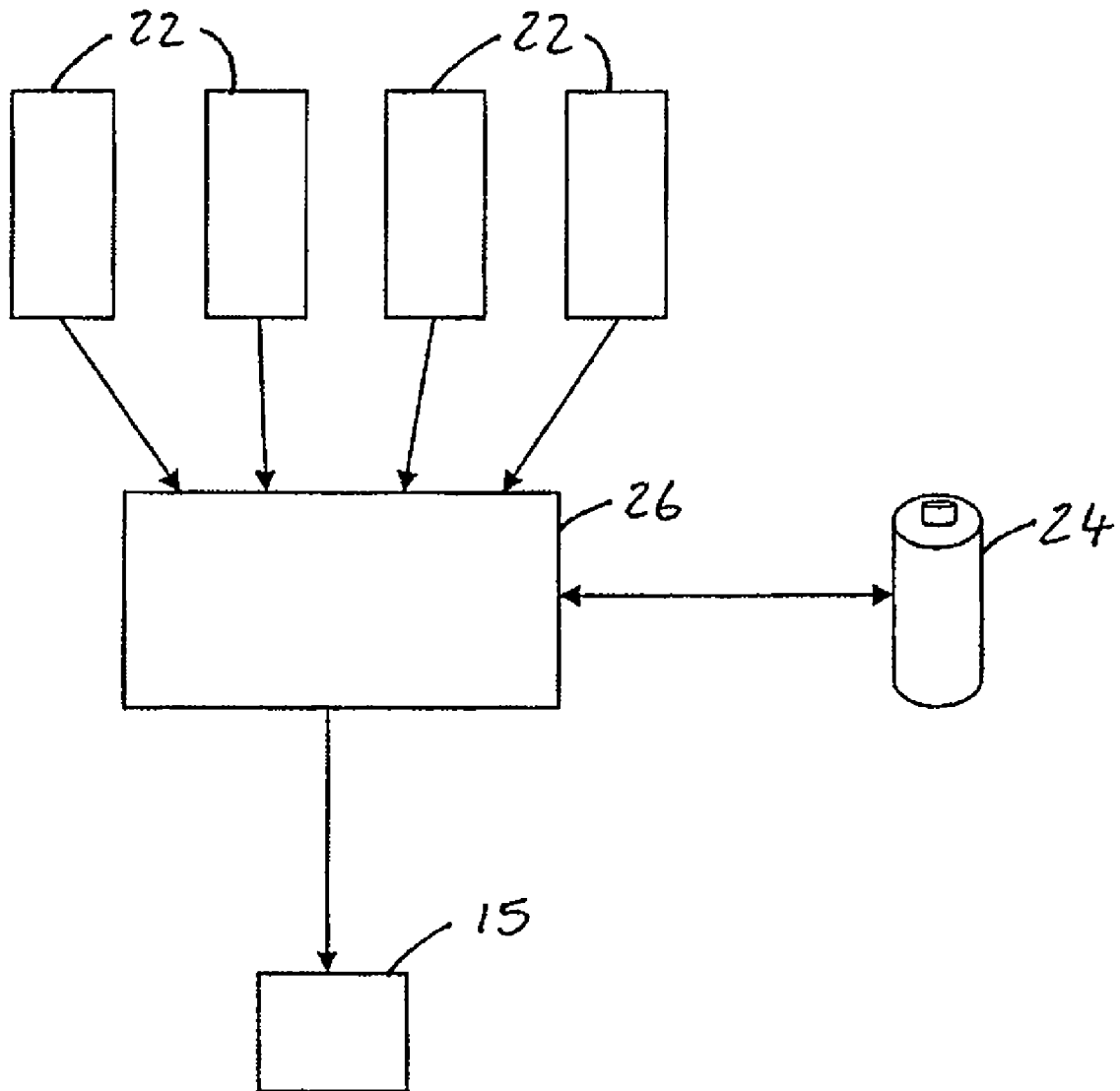

Fig. 2

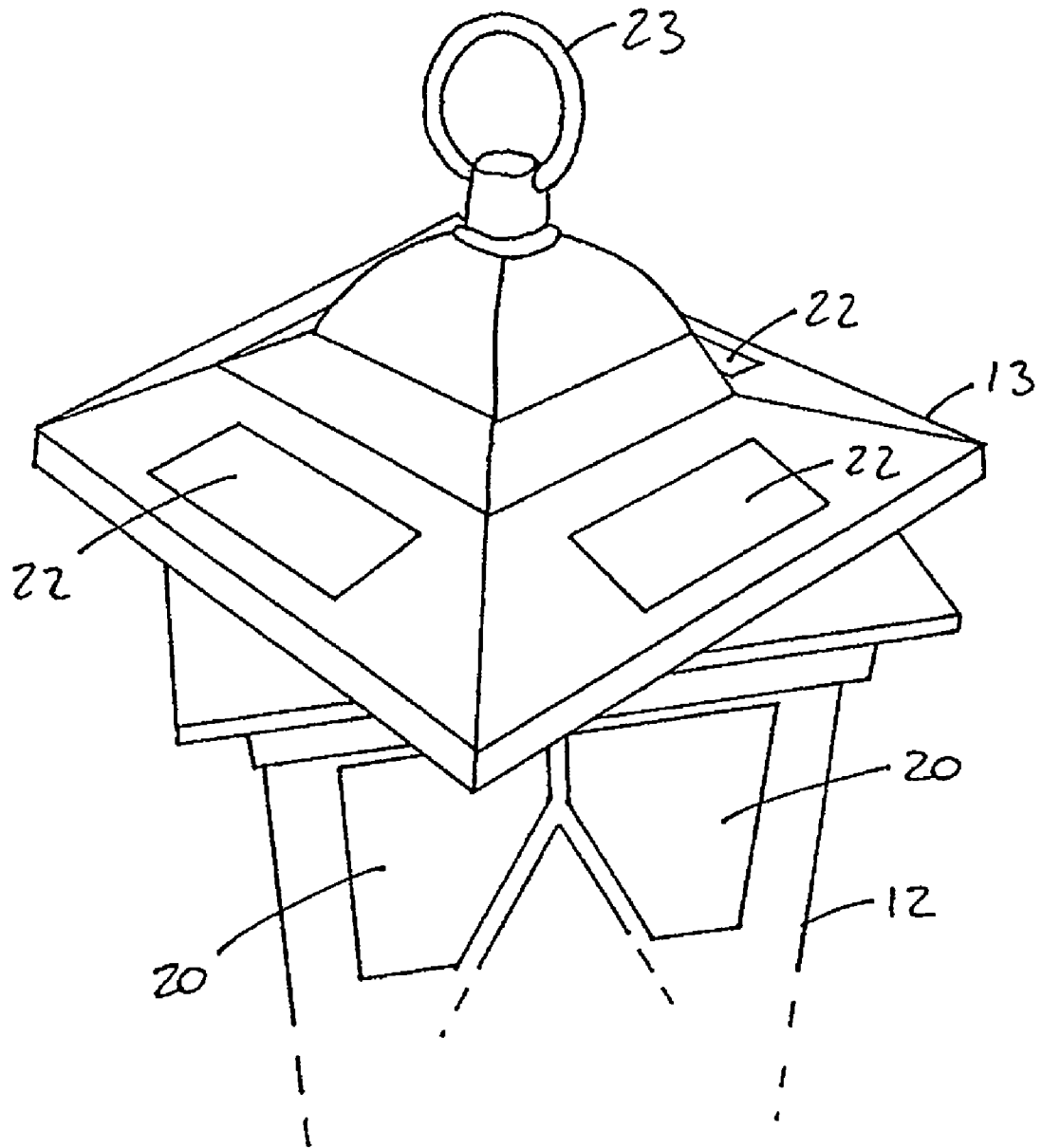

Fig. 3

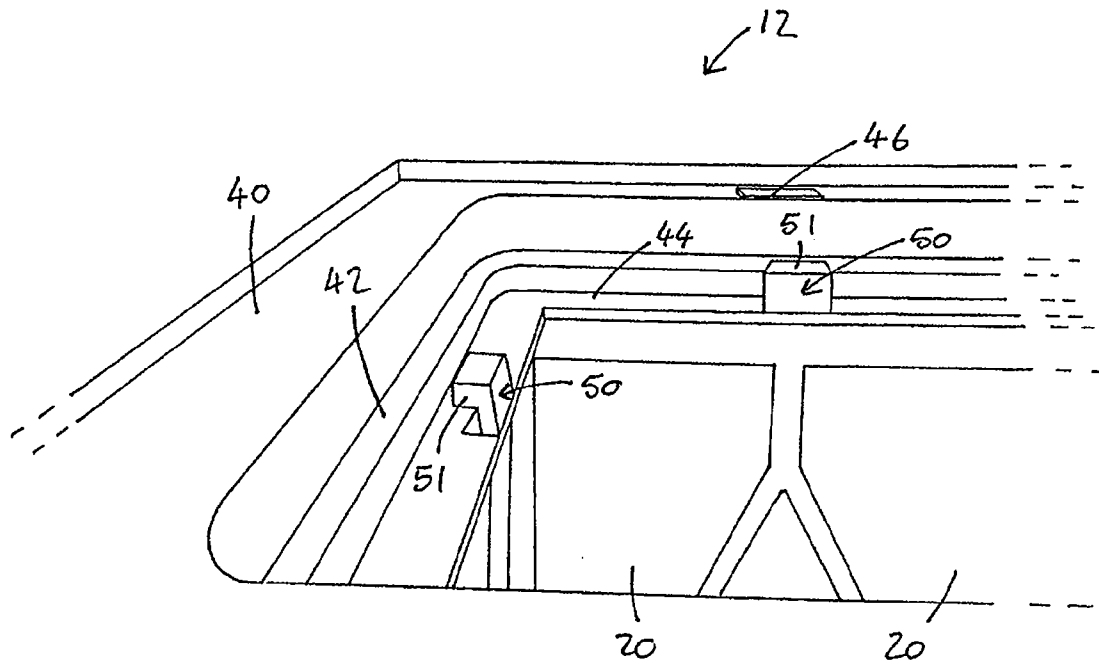

Fig. 4

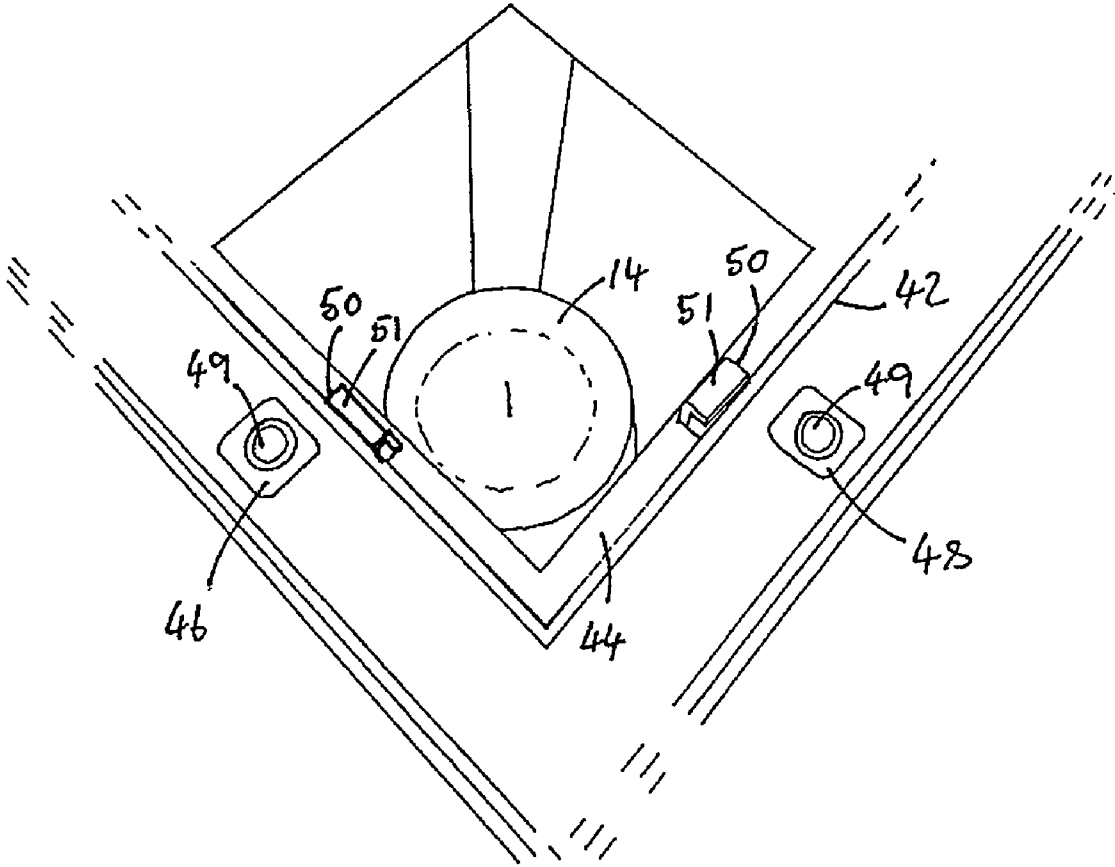

Fig. 5

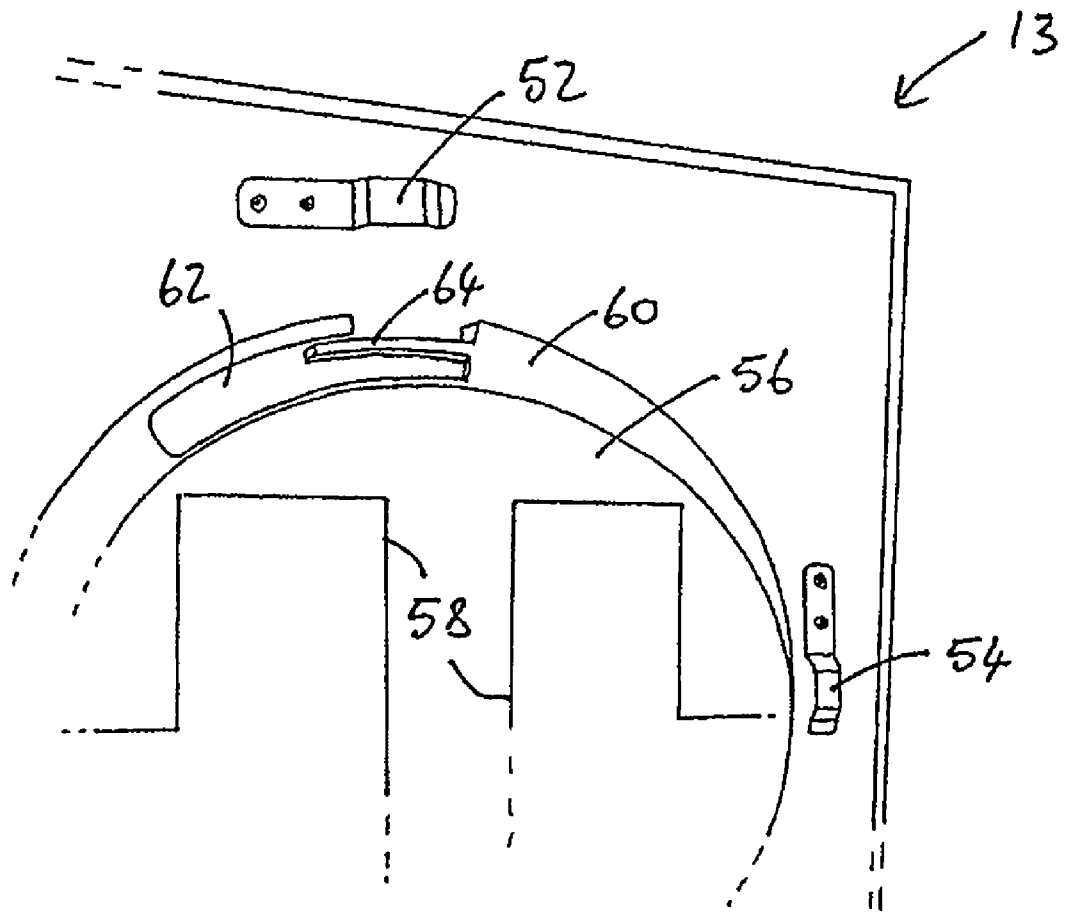

Fig. 6

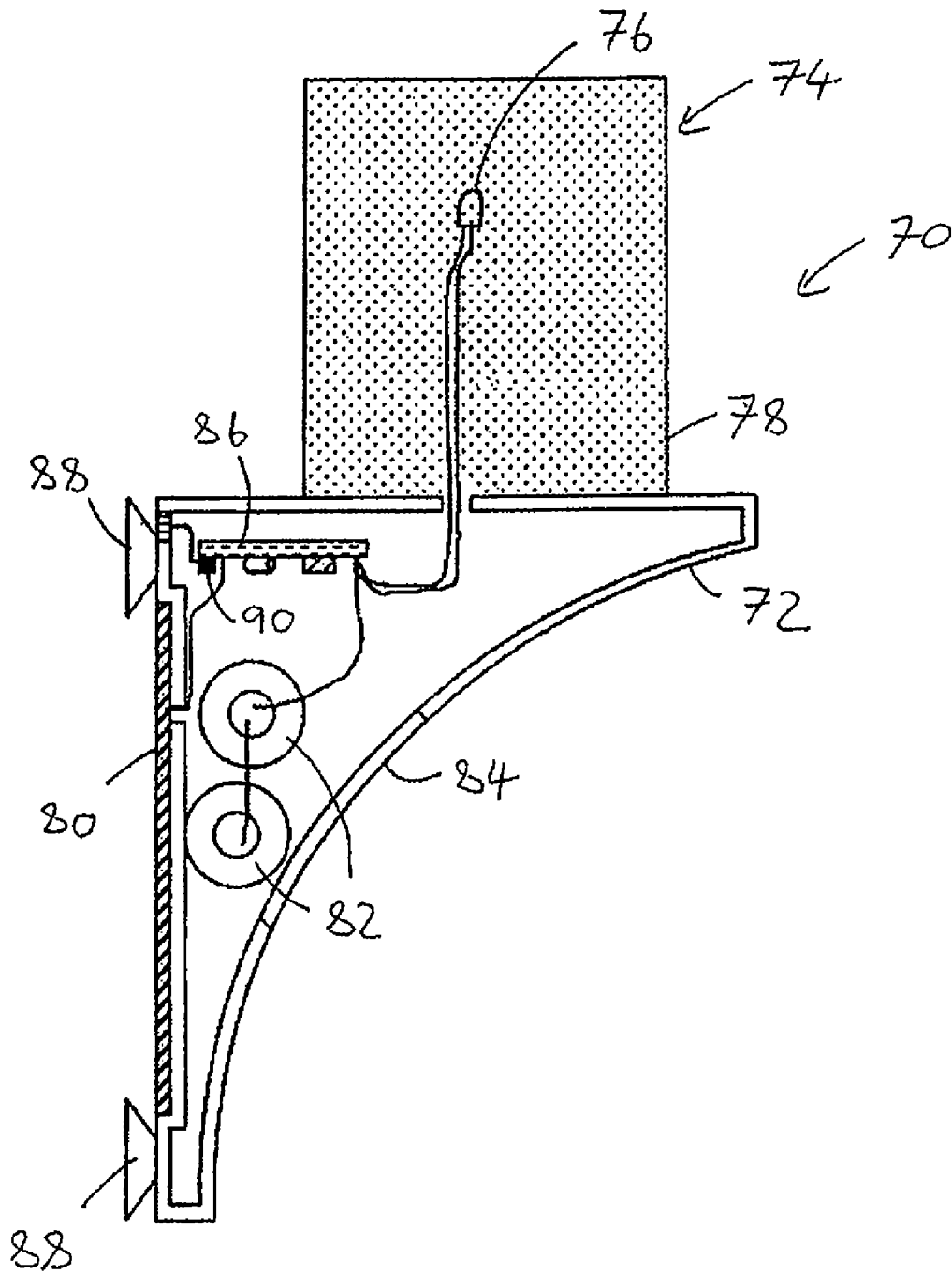

Fig. 7

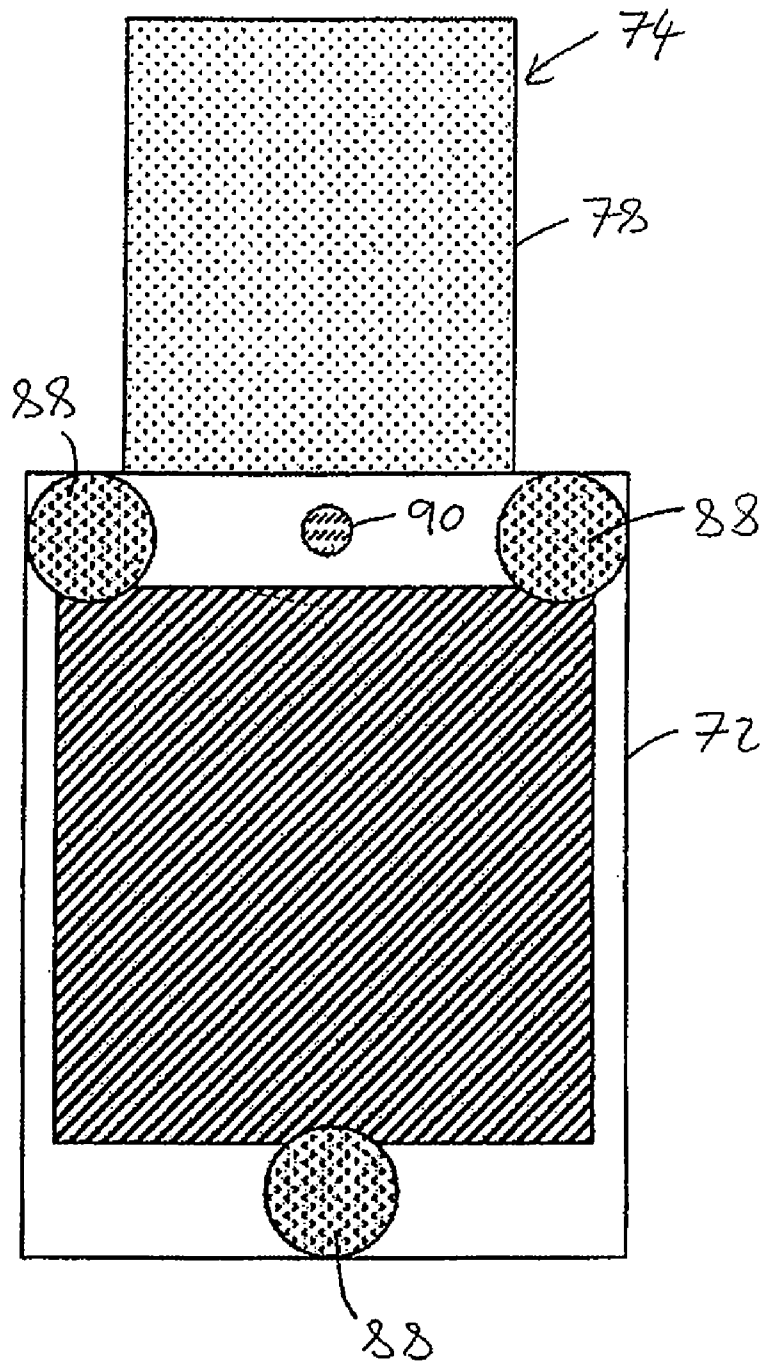

Fig. 8

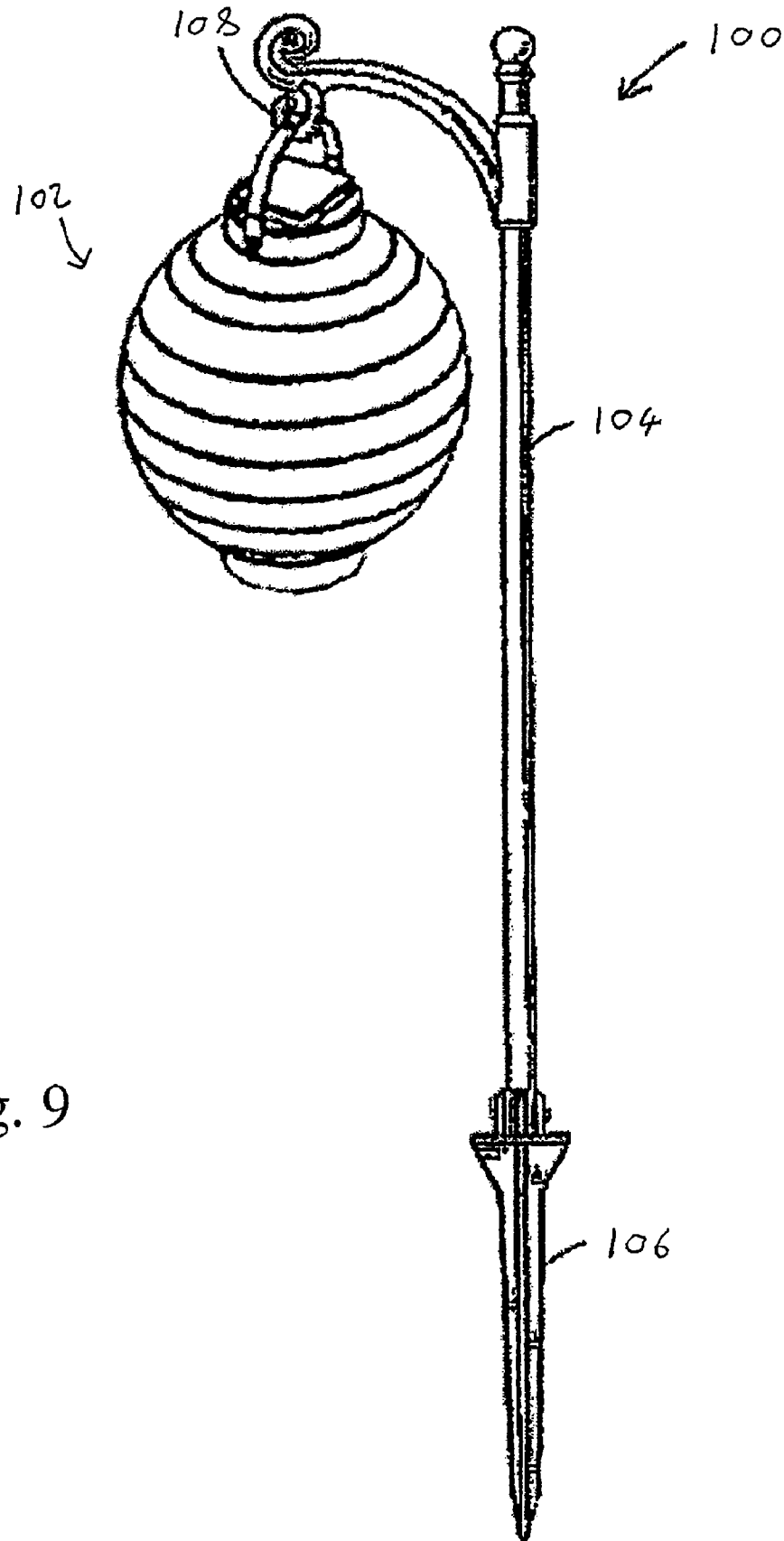

Fig. 9

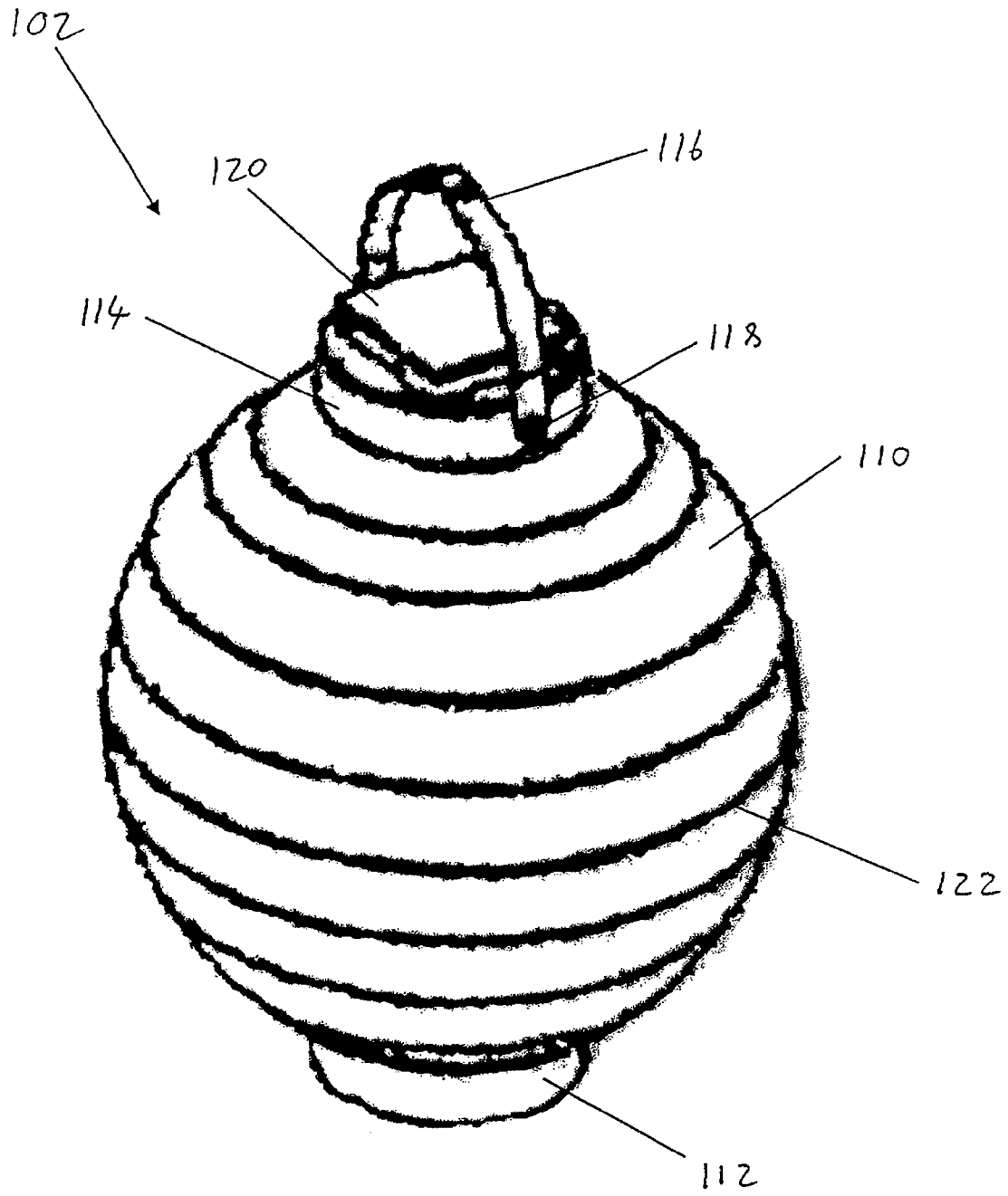

Fig. 10

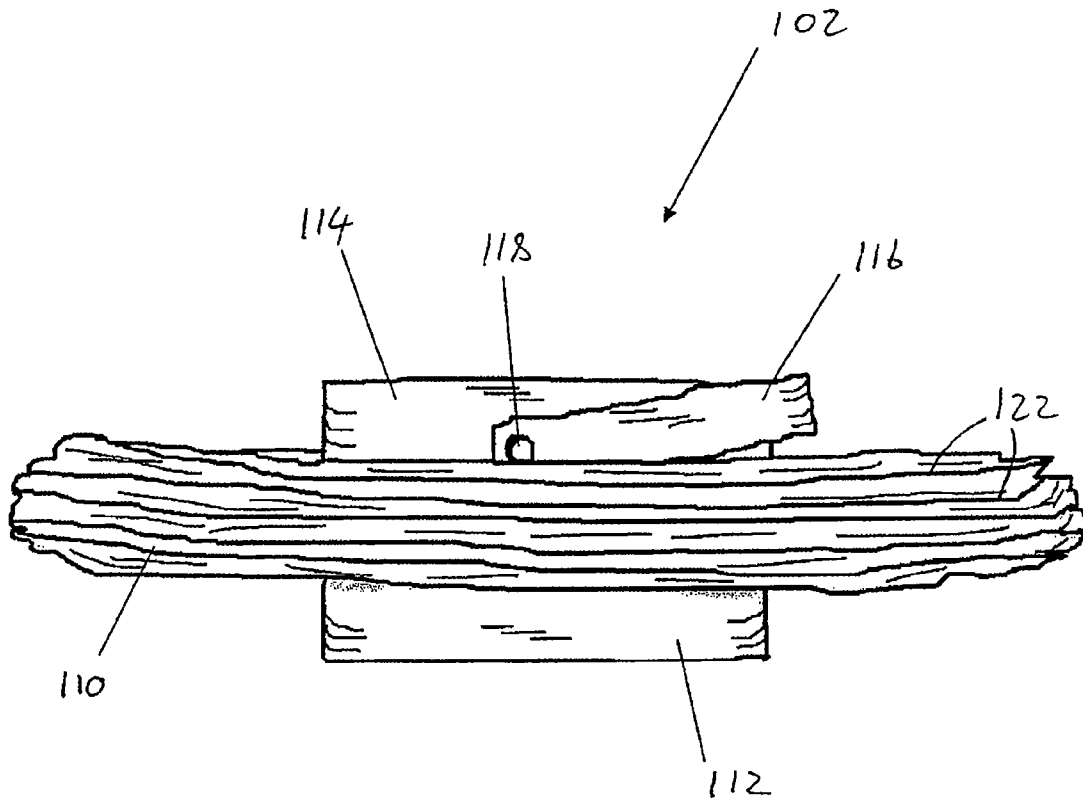

Fig. 11

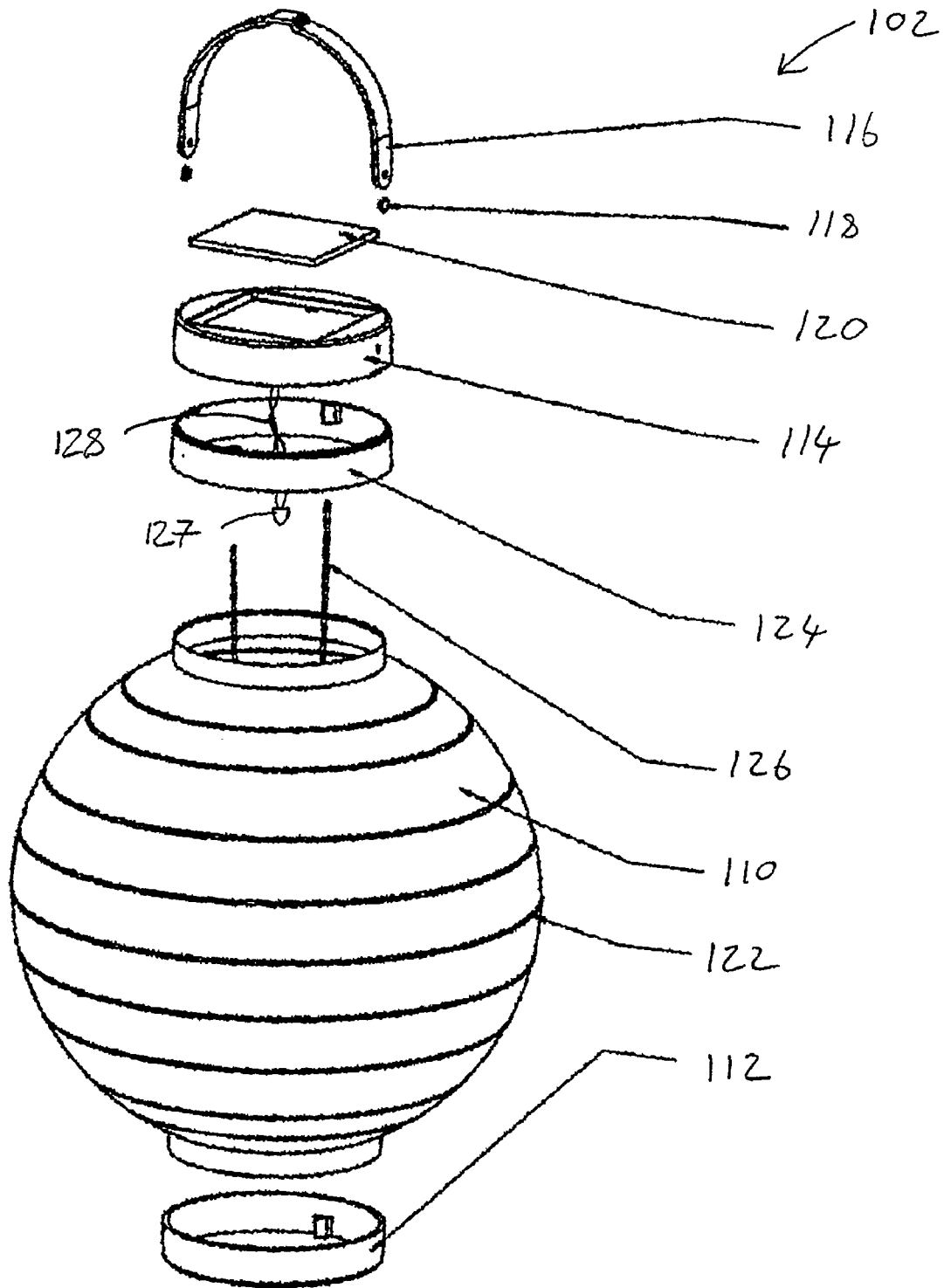

Fig. 12

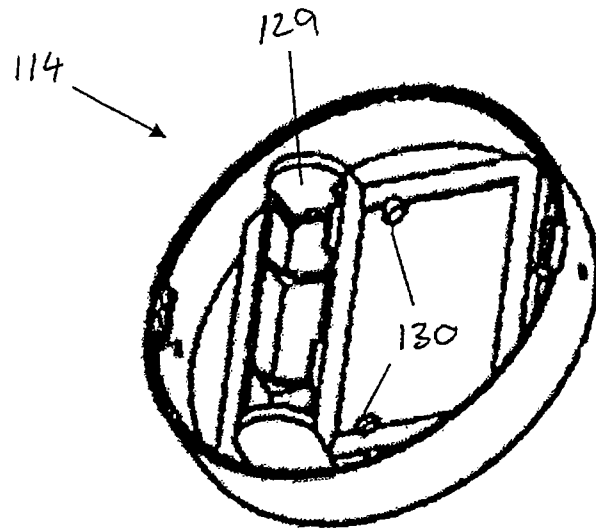

Fig. 13

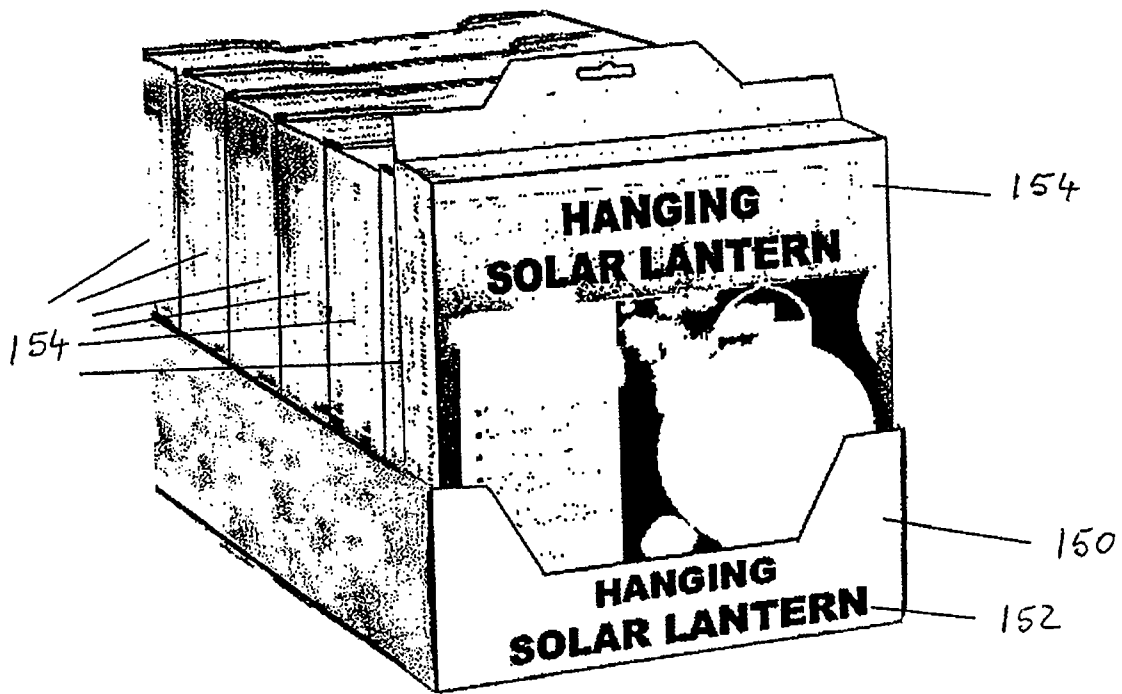

Fig. 14

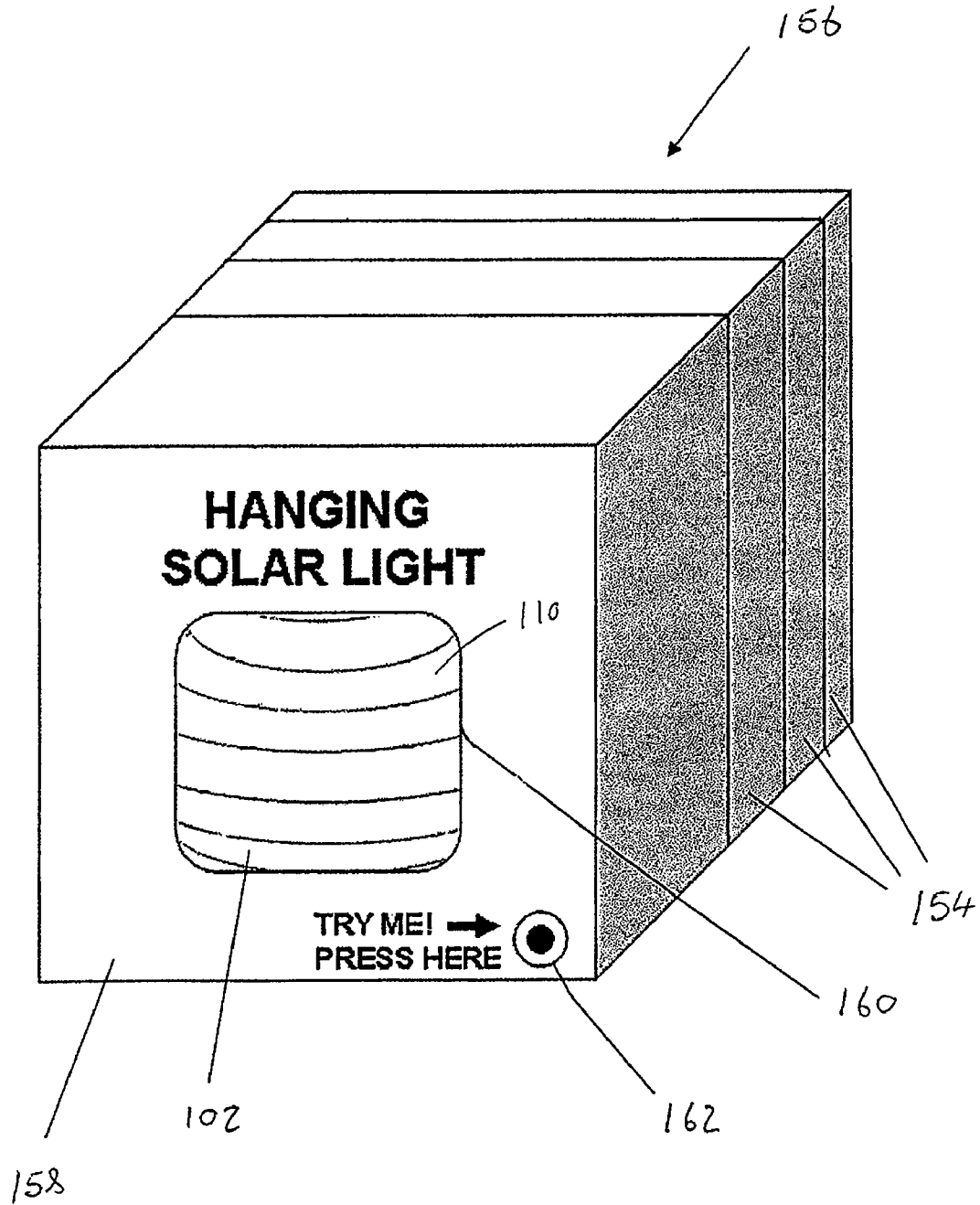

Fig. 15

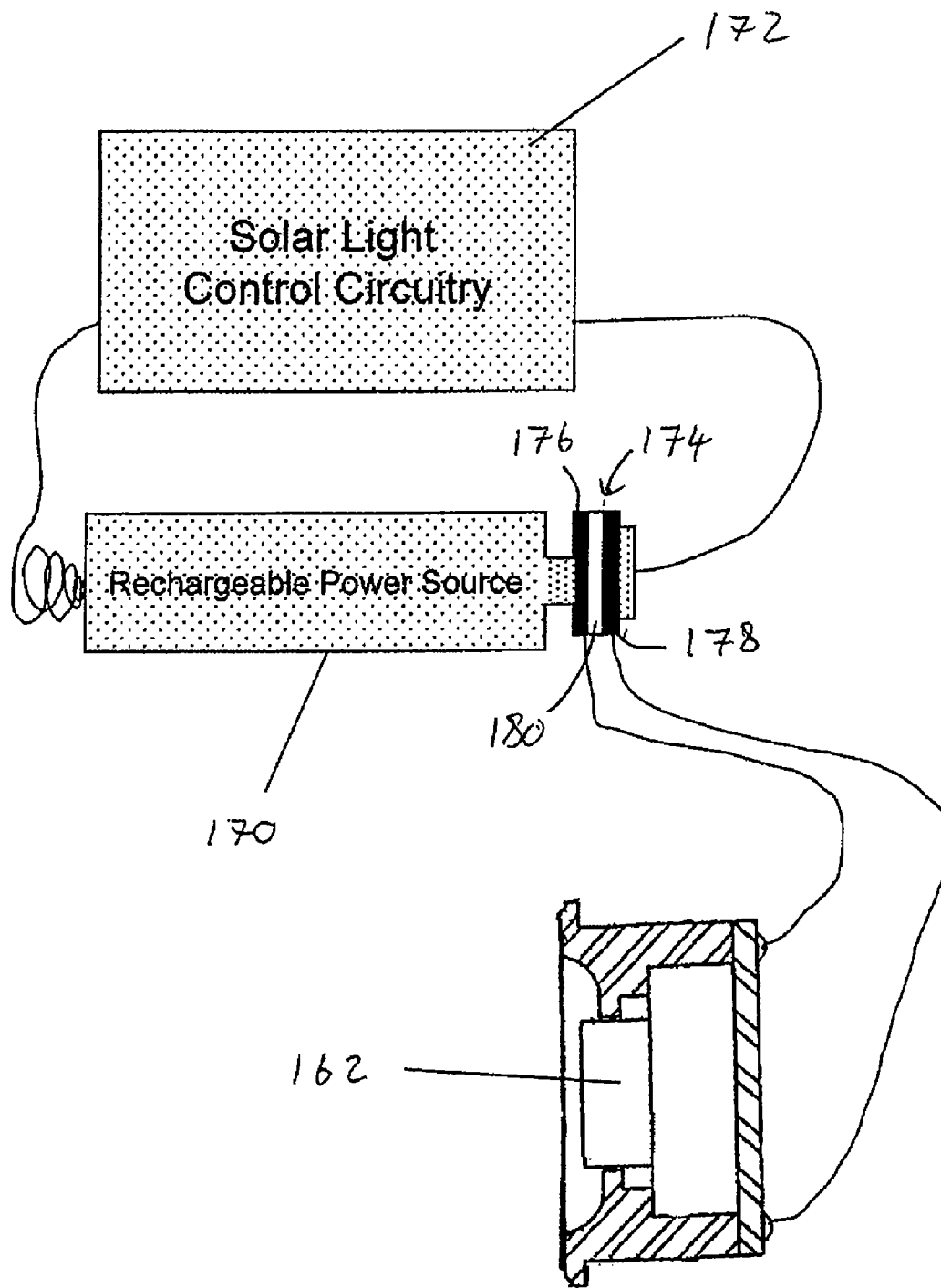

Fig. 16

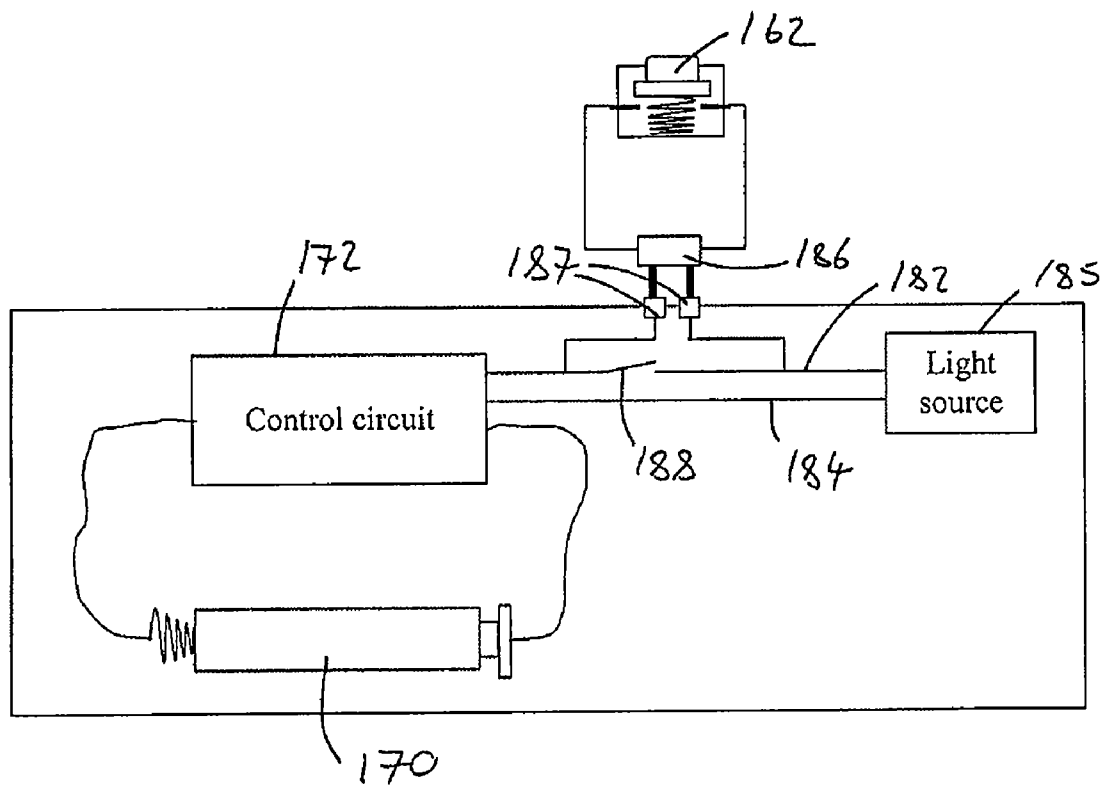

Fig. 17

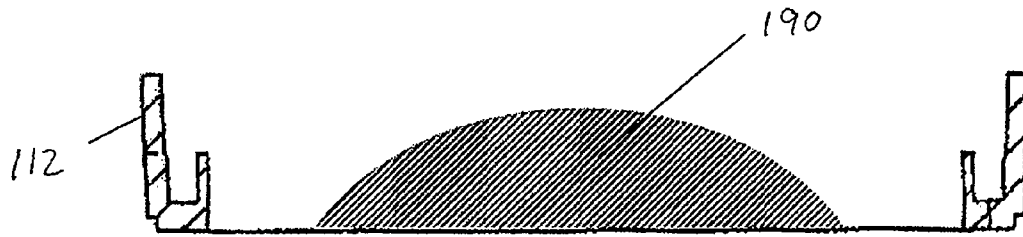

Fig. 18

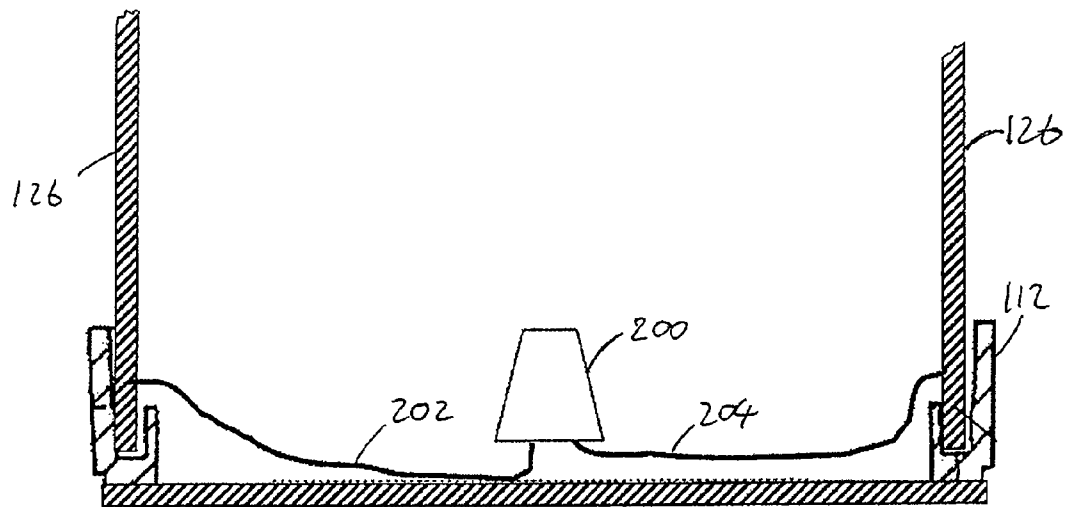

Fig. 19

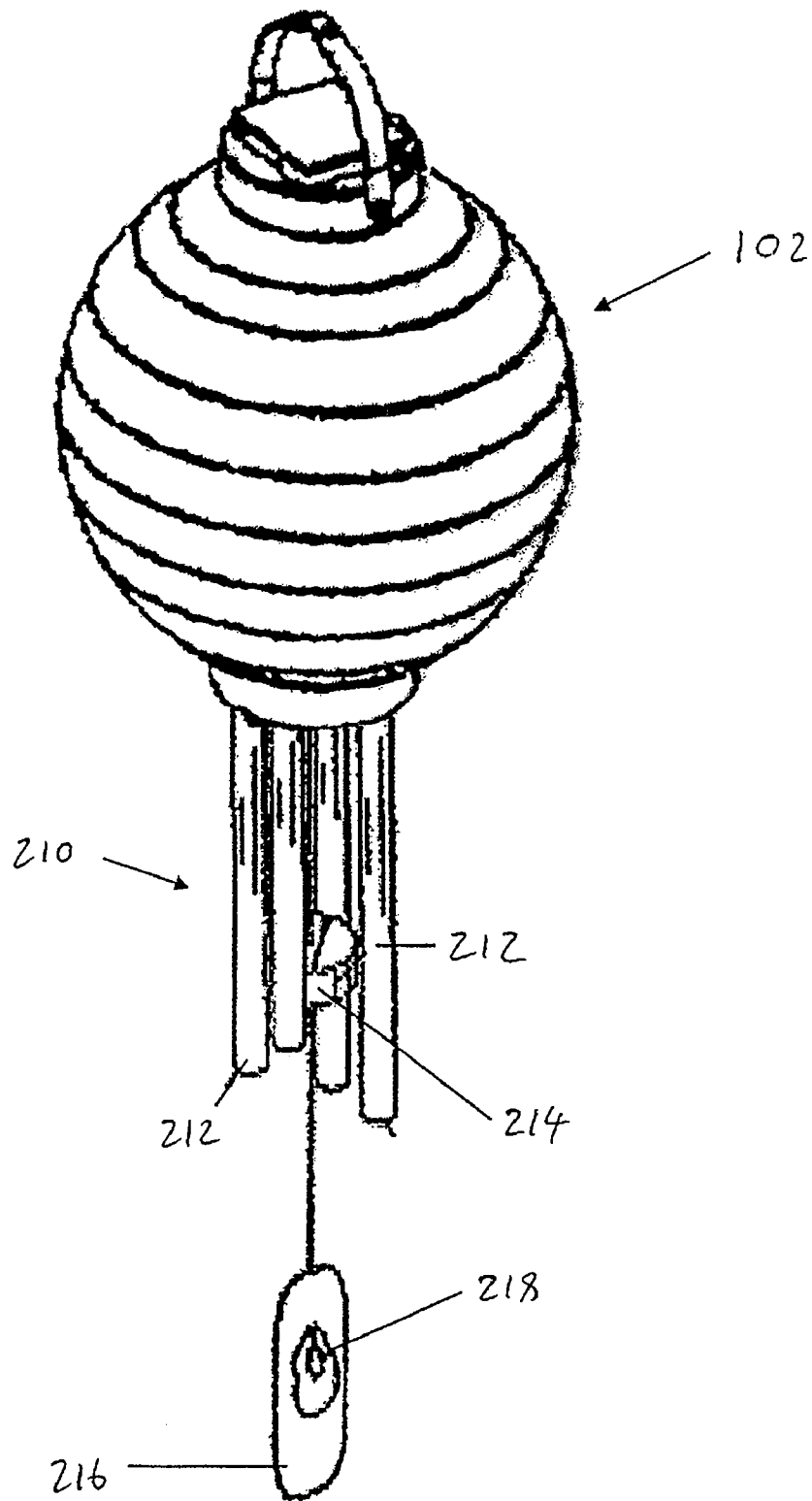

Fig. 20

1

LIGHT DEVICE**CROSS REFERENCE TO RELATED APPLICATION**

This invention is a Continuation-In-Part of pending U.S. patent application Ser. No. 11/057,077, filed on Feb. 11, 2005, which claims priority to Australian Patent Application No. 2004900700, filed on Feb. 13, 2004.

FIELD OF THE INVENTION

The present invention relates to a light device.

BACKGROUND OF THE INVENTION

It is known to provide a light device which includes a light source in the form of one or more LEDs, batteries arranged to supply power to the LEDs, and a control unit arranged to cause the LEDs to emit light which flickers. In one such prior art light device, the LEDs are disposed inside a lantern-type housing.

However, with this arrangement, the batteries are often disposed in a lid portion of the housing and electrically connected to the LEDs in the housing. As a consequence, the task of replacing the batteries is relatively cumbersome.

It is a long standing US tradition to place candles in the windows of a home during the Christmas holiday season so that the candles are visible from outside the windows.

Due to the danger associated with an open flame, electric candle systems have evolved to take the place of traditional candles. Such electrical candles are typically supported by an inner ledge or interior sill of a double hung window, or on ledges adjacent the windows.

However, electrical candles increase household electricity costs and conventional indoor electrical candles not properly fastened or mounted can be a fire and safety hazard.

As the cost of key components used in the construction of consumer solar garden pathway lights such as solar cells, light emitting diodes, and rechargeable batteries falls, a dramatically increasing factor in the total cost of low cost solar lights to a retailer is the cost of freight, in particular since the majority of consumer solar lights are made in low cost labor countries far from their intended customers. Due to the low weight to volume ratio, freight charges for solar lights are substantially based on physical volume. Further, sales of solar lights are mostly seasonal over the summer and consequently any excess inventory requires costly long term storage.

SUMMARY OF THE INVENTION

In accordance with a first aspect of the present invention, there is provided a light device comprising:

- a first portion configured so as to partially define a housing, the first portion being arranged so as to at least partially pass light therethrough and the first portion including first electrical contacts and a first locking device;
- a light emitting element disposed in the first portion and being electrically connected to the first electrical contacts; and
- a second portion including a battery compartment, second electrical contacts arranged so as to be in electrical connection with batteries disposed in the battery compartment during use, and a second locking device engageable with the first locking device so as to relea-

2

sibly fix the second portion to the first portion during use and thereby close the housing;

the arrangement being such that, during use, when the first and second locking devices are engaged with each other, the first electrical contacts electrically connect with the second electrical contacts so as to thereby electrically connect batteries disposed in the battery compartment during use to the at least one light emitting element.

One of the first and second locking devices may include at least one generally L-shaped member provided with an outwardly extending locking member, and the other of the first and second locking devices may include at least one cavity portion and at least one associated projection, each projection locating under a locking member when the first and second locking devices are engaged with each other.

Preferably, four L-shaped members are provided and four corresponding cavity portions and projections.

Preferably, the first locking device includes the at least one generally L-shaped member and the second locking device includes the at least one cavity portion and at least one associated projection.

In one arrangement, each first electrical contact includes a raised portion arranged so as to encourage good electrical contact with a second electrical contact during use.

In one arrangement, each second electrical contact is formed of resilient material so as to encourage good electrical contact with a first electrical contact during use.

In one arrangement, the first portion is a base portion of the light device, and the second portion is a lid portion of the light device.

In one arrangement, the base portion includes at least one transparent panel and a simulated candle having at least one light emitting element disposed in the simulated candle, the simulated candle being arranged so as to diffuse light passing therethrough from the at least one light emitting element.

In an alternative arrangement, the base portion includes at least one translucent panel and the at least one light emitting element is disposed in the base portion such that light from the at least one light emitting element is diffused by the at least one translucent panel. The or each translucent panel may be formed of frosted glass.

In one embodiment, the light device further comprises a control unit for causing the at least one light emitting element to emit flickering light. The light device may further be arranged such that the control unit is activatable and deactivatable under control of a user so as to activate or deactivate flickering of the at least one light emitting element.

The or each light emitting element may be an LED. Each LED may be arranged so as to emit yellow or amber coloured light.

In one arrangement, the light device includes a solar power converting device arranged to convert solar power to electrical power, and an electrical power storage device arranged to store electrical power provided by the solar power converting device.

The light device may be of lantern-type appearance.

In accordance with a second aspect of the present invention, there is provided a light device comprising:

- a housing portion arranged to receive at least one rechargeable electrical power storage device;
- a light source which receives electrical power from the or each electrical power storage device disposed during use in the housing portion;

3

a solar power converting device arranged to convert solar power to electrical power for recharging the or each electrical power storage device disposed during use in the housing portion; and

a fixing device arranged to facilitate fixing of the light device to a window pane so that the light source is visible through the window pane;

wherein the solar power converting device is disposed relative to the light device such that when the light device is fixed to an inwardly facing side of a window pane, the solar power converting device is disposed adjacent and substantially parallel to the window pane.

In one arrangement, the fixing device comprises at least one suction cup. Three suction cups may be provided disposed adjacent a periphery of the solar power converting device.

In one arrangement, the light source includes an at least partially transparent casing and at least one light emitting element disposed in the casing, the casing being arranged so as to pass or at least partially diffuse light passing there-through from the at least one light emitting element.

In one embodiment, the light device further comprises a control unit for causing the at least one light emitting element to emit flickering light. The light device may further be arranged such that the control unit is activatable and deactivatable under control of a user so as to activate or deactivate flickering of the at least one light emitting element.

The or each light emitting element may be an LED. Each LED may be arranged so as to emit yellow or amber coloured light.

In accordance with a third aspect of the present invention, there is provided a light device arranged to receive at least one rechargeable electrical power storage device, the light device comprising:

a flexible body portion movable between an expanded configuration and a contracted configuration and defining an enclosure when the body portion is in the expanded configuration, the body portion being at least partially transparent or translucent;

at least one light emitting element which receives electrical power from the or each electrical power storage device disposed during use in the light device, the light emitting element being arranged so as to generate light which passes outwardly of the light device through the body portion; and

a solar power converting device arranged to convert solar power to electrical power for recharging the or each electrical power storage device disposed during use in the light device;

wherein the light device is disposable in an expanded configuration or a contracted configuration by respectively expanding or contracting the body portion.

The body portion may include at least one strengthening frame arranged to encourage the body portion to maintain a desired shape when the body portion is in the expanded configuration.

The light device may further comprise at least one support element arranged to restrict the maximum distance between upper and lower portions of the body portion so as to thereby encourage the body portion to maintain a desired shape when the body portion is in the expanded configuration.

In one arrangement, the light device further comprises a transparent or translucent member, which may be a flexible clear plastic acetate lens, provided with indicia, patterns and so on, the transparent or translucent member being remov-

4

ably positioned in the body portion such that during operation the indicia and/or patterns appear on the surface of the body portion.

In one arrangement, the body portion includes indicia and/or patterns.

In one embodiment, the light device further comprises a control unit for causing the at least one light emitting element to emit flickering light. The light device may further be arranged such that the control unit is activatable and deactivatable under control of a user so as to activate or deactivate flickering of the at least one light emitting element.

The or each light emitting element may be an LED. Each LED may be arranged so as to emit yellow or amber coloured light.

BRIEF DESCRIPTION OF THE DRAWINGS

The present invention will now be described, by way of example only, with reference to the accompanying drawings, in which:

FIG. 1 is a diagrammatic perspective view of a light device in accordance with an embodiment of the present invention;

FIG. 2 is a block diagram showing components of the light device shown in FIG. 1;

FIG. 3 is a diagrammatic perspective view of the light device shown in FIG. 4 with a lid portion of the light device shown rotated relative to a base portion of the light device;

FIG. 4 is a diagrammatic perspective view of an upper portion of the base portion the light device shown in FIG. 1;

FIG. 5 is a further diagrammatic perspective view of the upper portion of the base portion shown in FIG. 4;

FIG. 6 is a diagrammatic perspective view of a lower portion of the lid portion of the light device shown in FIG. 1;

FIG. 7 is a diagrammatic cross-sectional view of a light device in accordance with an alternative embodiment of the present invention;

FIG. 8 is a diagrammatic front view of the light device shown in FIG. 7;

FIG. 9 is a diagrammatic perspective view of a light assembly including a light device in accordance with a further alternative embodiment of the present invention;

FIG. 10 is a diagrammatic perspective view of the light device shown in FIG. 9, with the light device shown in an expanded configuration;

FIG. 11 is a diagrammatic representation of the light device shown in FIG. 10, with the light device shown in a contracted configuration;

FIG. 12 is a diagrammatic exploded perspective view of the light device shown in FIGS. 10 and 11;

FIG. 13 is a diagrammatic perspective view of an upper cap of the light device shown in FIGS. 9 to 12;

FIG. 14 is a diagrammatic perspective view of an arrangement for packaging the light device shown in FIGS. 9 to 13;

FIG. 15 is a diagrammatic perspective view of an alternative display package for the light device shown in FIGS. 9 to 13;

FIG. 16 is a schematic diagram of a test arrangement for facilitating testing of the light device by a user;

FIG. 17 is an alternative arrangement for facilitating testing of the light device by a user;

FIG. 18 is a diagrammatic cross-sectional view of an alternative lower cap of the light device shown in FIGS. 9 to 12;

5

FIG. 19 is a diagrammatic cross-sectional view of the light device shown in FIGS. 9 to 12 provided with an additional light emitting device; and

FIG. 20 is a diagrammatic perspective view of the light device shown in FIGS. 9 to 12 modified so as to include a

DETAILED DESCRIPTION OF AN EMBODIMENT OF THE INVENTION

Referring to the drawings, there is shown a light device 10 which includes a base portion 12 and a lid portion 13. The light device 10 is of lantern-type appearance.

Mounted on the lid portion and disposed inside the base portion 12 during use is a light source. In this example, the light source is in the form of a simulated candle 14 having one or more light emitting elements such as LEDs 15 disposed inside the simulated candle 14. The simulated candle 14 is arranged so that light passing through the simulated candle 14 from the light emitting elements is

diffused. The or each LED 15 may be of a type which emits yellow or amber light.

The base portion 12 includes transparent panels 20, although it will be understood that as an alternative to providing a simulated candle which diffuses light from the LEDs 15, a plurality of translucent panels may be provided to diffuse light passing through the panels during use. In this example, the translucent panels may be frosted glass, although it will be understood that other translucent panels may be used.

The light device 10 also includes a solar power converting device, in this example in the form of solar panels 22, which serves to convert solar power to electrical power. The solar panels 22 may be in the form of encapsulated polycrystalline PV solar panels or any other suitable solar power converting device.

The light device 10 also includes means, in this example a ring member 23, for facilitating hanging of the light device 10 from a structure. However, it will be understood that any suitable hanging means may be provided.

In an alternative embodiment or additionally, the light device 10 may include a spike extending downwardly from a lower wall portion 18 of the light device 10, the spike for example facilitating mounting of the light device 10 to a ground portion of a garden.

As shown in FIG. 2, electrical power supplied by the solar panels 22 serves to recharge a rechargeable power source, in this example rechargeable batteries 24 which may be NiCd batteries.

In order to coordinate supply of electrical power from the solar panels 22 to the rechargeable batteries 24 and from the rechargeable batteries 24 to the light source 14, a control unit 26 is provided.

The control unit 26 may also be arranged to sense the ambient light level, for example using a light dependent resistor 27, to cause illumination of the LED(s) 15 when the ambient light level falls below a predetermined level.

The light device 10 may also be arranged to receive power directly from an external power supply, for example by providing the light device 10 with an appropriate step-down transformer (not shown) connectable to mains AC electrical power and appropriate AC to DC conversion circuitry.

In order to cause the or each LED 15 in the light source to flicker, the control unit 26 may be provided with an inverter (not shown) and the inverter controlled so as to generate an alternating current arranged so as to cause the

6

LED(s) 15 to mimic the characteristic flicker of a flame. Alternatively, an irregular oscillating input may be applied to a switching transistor so as to cause irregular switching of current through the LED(s) 15. Appropriate biasing signals for the switching transistor may be generated using multiple oscillators, each of which is arranged to oscillate at a different frequency. For example, a base of the switching transistor may be connected to outputs of multiple Schmitt trigger oscillators arranged to oscillate at different frequencies, the Schmitt trigger oscillators for example being constructed using a CMOS 40106 hex inverting Schmitt trigger integrated circuit.

The control unit 26 may be controllable so that the light source may be caused to flicker or to not flicker, for example in response to input from a manually operable switch.

It will be understood that the simulated candle 14 causes the flickering light to diffuse and thereby provide an effect which more closely resembles the effect produced by a flickering candle than light devices known hitherto.

The lid portion 13 is removably attachable to the base portion 12 by rotating the lid portion 13 relative to the base portion 12, as shown in FIG. 3.

As shown more particularly in FIGS. 4 and 5, an upper portion of the base portion 12 is of generally recessed configuration and includes first, second and third ledge portions 40, 42 and 44 respectively.

Mounted on the first ledge portion 40 are first electrical contacts 46, 48 electrically connected to the light source, each of the first electrical contacts 46, 48 including a raised portion 49 shown more particularly in FIG. 5. The first electrical contacts 46, 48 are formed of resilient electrically conductive material.

Integral with the third ledge portion 44 are a plurality of first locking device 50, in this example in the form of four generally L-shaped members (only two of which are shown in FIGS. 4 and 5) arranged such that respective locking members 51 of the L-shaped members extend outwardly of the base portion 12.

As shown more particularly in FIG. 6, a lower portion of the lid portion 13 includes second electrical contacts 52, 54 respectively, and a battery compartment 56 provided with closure members 58 removable from the battery compartment 56 so as to facilitate insertion of batteries (not shown) into the battery compartment 56.

The lower portion of the lid portion 13 also includes a lip portion 60 extending around the periphery of the battery compartment 56. The lip portion 60 includes second locking devices, in this example in the form of a cavity portion 62 and a projection 64.

It will be understood that the first and second locking devices 50, 62, 64 are arranged such that when the lid portion 13 is disposed on the base portion 12 and rotated relative to the base portion 12, the first and second locking devices mechanically engage with each other so as to fix the lid portion 13 relative to the base portion 12. In this example, when the lid portion 13 is disposed on the base portion 12 and rotated relative to the base portion 12, the L-shaped member 50 locates in the cavity portion and the projection 64 locates under the locking member 51. However, it will be understood that other locking arrangements are envisaged, the important aspect being that the base portion 12 and the lid portion 13 are provided with complimentary locking devices arranged to facilitate mechanical engagement between the base portion 12 and the lid portion 13.

It will also be understood that when the lid portion 13 is disposed on the base portion 12 and rotated relative to the base portion 12, the first electrical contacts 46, 48 make

electrical contact with the second electrical contacts **52, 54** so that electrical power from the batteries is supplied to the light source. The resilience of the first electrical contacts **46, 48** and the presence of the raised portions **49** on the second electrical contacts **52, 54** ensures that good electrical contact is achieved between the first electrical contacts **46, 48** and the second electrical contacts **52, 54** during use.

It will be appreciated that the lid portion **13** is both mechanically and electrically connectable to and disconnectable from the base portion **12** by disposing the lid portion **13** on the base portion **12** and rotating the lid portion relative to the base portion **12**. In this way, the lid portion **13** serves as a self-contained power source and in embodiments which include solar panels **22** and rechargeable batteries, the lid portion serves as a self-contained solar rechargeable power source.

Furthermore, it will be appreciated that since the lid portion **13** is self-contained, the task of replacing the batteries is less cumbersome than with comparable light devices known hitherto.

Moreover, the invention is also applicable to other light devices and other electrical apparatus in general wherein it is desirable to provide a self-contained power source which is both mechanically and electrically connectable to an electrical apparatus requiring electrical power.

A light device **70** in accordance with an alternative embodiment is shown in FIGS. **7** and **8**. The light device **70** is of a type which is mountable adjacent an interior face of a window during use so that light emanating from the light device **70** is viewable from a location outside the window.

The light device **70** includes a housing **72** which may be formed of metal, plastics, wood or any other suitable material, and a light source **74** mounted above and supported by the housing **72**. In this example, the light source **74** includes one or more light emitting elements, in this example in the form of LEDs **76**, disposed inside a generally cylindrical casing **78**. The casing **78** may be formed of transparent or translucent material and in this example is formed of lightweight thermoplastic polymer material such as ABS or polypropylene.

Mounted on the housing **72** is a solar power converting device, in this example a solar panel **80**. The solar panel **80** is disposed on the housing **72** such that during use the solar panel **80** extends in a generally vertical direction. The solar panel **80** may be formed of amorphous silicon or crystalline silicon.

Disposed in the housing **72** is a rechargeable power source, in this example in the form of two rechargeable batteries **82** which may be nickel cadmium batteries, nickel metal hydride batteries, rechargeable alkaline batteries, lead acid batteries, lithium ion batteries or any other suitable rechargeable electrical power source. A removable lid **84** is also provided so as to allow access to the housing **72** and thereby the rechargeable batteries **82**.

The light device **70** also further includes a circuit board **86** provided with operative components arranged to cause the LED(s) **76** to illuminate in accordance with a predetermined scheme. For example, the operative components may cause the LED(s) **76** to operate in a similar way to the above embodiment described in relation to FIGS. **1** to **6**, wherein the batteries **82** are recharged using power generated by the solar panels **80**, and power in the batteries **82** is used to illuminate the LED(s) **76** only when the ambient light level has fallen below a predetermined level. As with the embodiment shown in FIGS. **1** to **6**, this may be achieved using a light dependent resistor **90** which provides an appropriate signal to the circuit board **86** to effect switching of power to

the light source **74**. The operative components may also be arranged so as to cause the LED(s) **76** to flicker, for example so as to mimic the characteristic flicker of a flame, so as to vary the intensity or colour of one or more LED(s) **76** and so on, as described above in relation to the embodiment shown in FIGS. **1** to **6**.

The light device **70** also includes fixing means **88** arranged to facilitate removable fixing of the light device **70** to an interior face of a window. In this example, the fixing means **88** is in the form of three suction cups **88** disposed adjacent a periphery of the solar panel **80**. In this way, the light device **70** is removably fixable to an interior face of a window such that the solar panel **80** is disposed immediately adjacent and generally parallel to the window. This enables light passing through the window to fall directly on the solar panel **80** and thereby provide efficient charging of the rechargeable power source **82** whilst enabling light from the light source **74** to be readily visible from outside the window.

A light assembly **100** including a light device **102** in accordance with a further alternative embodiment is shown in FIGS. **9** to **20**.

The light device **102** in this example is suspended on a support device **104** provided with a stake **106** and a hook **108**. However, it will be understood that various types of support device are envisaged.

As shown more particularly in FIGS. **10** to **13**, the light device **102** includes a hollow body **110** which is closed at lower and upper ends by lower and upper caps **112** and **114** respectively. The light device **102** is suspended from the hook **108** using a strap **116** which is pivotably connected to the upper cap **114** at pivot connections **118**. Disposed on the upper cap **114** is a solar panel **120**. In the present example, the body **110** is a diffuser body formed of material which diffuses light passing through the body **110**, and which is sufficiently flexible that the light device **102** is disposable in an expanded configuration as shown in FIG. **10** and a contracted configuration as shown in FIG. **11**. For this purpose, the body **110** may be formed of translucent flexible plastics material having optical transmissive properties similar to rice paper.

In the present example, in order to assist in maintaining a desired shape when the light device **102** is disposed in the expanded configuration, one or more frame members **122** may be provided, in this example a plurality of circular frame member **122** disposed at evenly spaced locations between the lower and upper caps **112, 114**.

The frame members **122** may be formed of any suitably strong material which is preferably relatively resistant to corrosion. The body **110** likewise is preferably formed of relatively weather resistant material, and may be provided with indicia, patterns, artwork, and so on. For example, the body **110** may be printed with a pumpkin design for Halloween, snowflakes for Christmas, and so on.

As shown in FIG. **11**, since the strap **116** is pivotably connected to the upper cap **114**, the strap **116** is able to lie generally parallel to the frame members **122** when the light device **102** is in the contracted configuration.

As shown more particularly in FIG. **12**, the light device **102** in this example includes flexible support elements **126** which extend between the upper cap **114** and the lower cap **112**, the support elements **126** serving to restrict the maximum distance between the upper and lower caps **112, 114** so as to thereby assist in maintaining the shape of the body **110** when the light device **102** is in the expanded configuration.

As shown in FIG. **12**, the light device **102** may further include an inner cap **124** connected to the body **110** and

releasably engageable with the upper cap **114**. In this way, operative components of the light device **102** may be selectively engaged with different diffuser bodies depending on the desired effect.

In addition or alternatively, a transparent or translucent member, which may be a flexible clear plastic acetate lens, provided with indicia, patterns and so on may be removably positioned in the body **110** such that during operation the indicia and/or patterns appear on the surface of the body **110**. One embodiment has one or more partially transparent acetate sheets or a similar material with printed logos, words, or designs on them. The sheets may be polygonal or a cylindrical or any other shape.

The operative components disposed in the upper cap **114** include a light emitting device **127**, in this example an LED, the LED extending into an enclosure defined by the body **110** and being supported by flexible electrical wires **128**.

One or more LEDs **127** may be provided and the or each LED may be of a type which emits yellow or amber light. In addition, operative components of the light device **102** disposed in the upper cap **114** may be arranged so as to illuminate the or each LED in accordance with a predetermined scheme. For example, the operative components may be arranged to illuminate the or each LED in a manner as described in co-pending U.S. patent application Ser. No. 10/789,488 or U.S. Ser. No. 11/102,229 by the present applicant, the contents of which are hereby incorporated by reference.

While the present embodiment is described in relation to a generally spherical body **110**, it will be understood that any shape is envisaged such as ovoid, cylindrical, conical, rectangular, cuboid, and so on.

The light device **102** includes operative components disposed in the upper cap **114** which control and determine the illumination scheme of the or each LED **127**. The operative components may be arranged so as to operate in the same way as the operative components described in relation to FIGS. **1** to **6** of the first embodiment described above. For this purpose, the operative components include a solar panel **120** mounted in the upper cap **114** and a battery compartment **129** formed in the upper cap **114**. Apertures **130** are also provided in the upper cap **114** for receiving electrical wires associated with the solar panel **120**.

As shown in FIG. **18**, in a modified version of the light device **102**, a reflector **190**, in this example of generally convex configuration, is disposed in the lower cap **112** so as to reflect a portion of light from the lower cap **112** back through the body **110**.

As shown in FIG. **19**, in a further modified version of the light device **102**, an additional light emitting device **200**, which may be an LED, may be provided adjacent the lower cap **112**, the light emitting device **200** being provided with electrical power through first and second wires **202**, **204**, each of which extends through one of the support elements **126**, or through the support elements **126** themselves. In the variation shown in FIG. **19**, the light emitting device **200** is disposed inwardly of the light device **102**. However, it will be understood that as an alternative, the light emitting device **200** may be disposed outwardly of the lower cap **112** and, for example, directed downwards. Such an additional external light emitting device **200** may be connected to the lower cap **112** so as to be user adjustable to selectively vary the lighting direction.

A display package **150** including package indicia **152** and several device packages **154** is shown in FIG. **14**. Each device package **154** includes a light device **102** in a contracted configuration. As can be seen, by configuring the

light device **102** so as to be positionable in a contracted configuration, it is possible to dispose the light device **102** in relatively compact packaging.

An alternative display package **156** is shown in FIG. **15**. With this package **156**, several device packages **154** having a light device **102** disposed in the contracted configuration are provided, and one device package **158** with the light device **102** disposed in an expanded configuration is provided. In this way, it is possible to save space by providing the majority of the light devices **102** in the contracted configuration, whilst enabling a prospective purchaser to view the light device **102** in the expanded configuration. Support devices for use with the light devices **102** may be packaged separately to the device packages **154**, **158**.

As an alternative, only one device package may be provided, with one device in an expanded configuration and several devices in a contracted configuration disposed in the package. Individual light devices may be separated using any suitable divider, for example formed of cardboard material.

The device package **158** includes a window **160** and, in this example, a test button **162** which, when pressed, supplies power to the LED **127** so as to illuminate the body **110**.

The arrangement for enabling a user to test operation of the light device **102** by pressing the button **162** may be of a type described in co-pending U.S. patent application Ser. No. 11/107,940, the contents of which are hereby incorporated by reference.

As shown in FIG. **16**, the test arrangement is associated with a rechargeable power source **170** which may be a rechargeable battery, and the light device includes control circuitry **172** arranged to control and determine operation of the light device **102**, for example so as to cause the light device **102** to operate in a similar way to the embodiment described above in relation to FIGS. **1** to **6**.

Disposed between the rechargeable power source **170** and the control circuitry **172** is an insert **174** which has a first conductor **176** connected to the rechargeable power source **170** and the button **162**, a second conductor **178** connected to the control circuitry **172** and the button **162**, and an insulator **180** disposed between the first and second connectors. The arrangement is such that the rechargeable power source **170** is isolated from the control circuitry **172** until the button **162** is pressed. When the button **162** is pressed, an electrical connection is made between the first and second conductors **176**, **178** and thereby between the rechargeable power source and the control circuitry **172**.

An alternative test arrangement is shown in FIG. **17**, wherein instead of disposing the button **162** between the rechargeable power source **170** and the control circuitry **172**, the button **162** is disposed in parallel with one of two power supply wires **182**, **184** extending from the control circuitry **172** to a light source **185**, in this example a first power supply line **182**. The button **162** is connected to a plug **186** engageable with and disengageable from a socket **187**, and disposed in line with the first power supply line **182** is a bypass switch **188**. The arrangement is such that during a test mode, the plug **186** is engaged in the socket **187** and the bypass switch **188** is open. In this mode, the light source is prevented from receiving electrical power until the button **162** is pressed. During an operation mode, the plug **186** is disengaged from the socket **187** and the switch **188** is moved to a closed position. In this mode, the light source receives power through the first and second power supply lines, with an electrical current passing through the closed switch **188**.

As with the light device **102**, the support device **104** may be configured so as to be collapsible, in particular by

configuring the support device **104** such that parts of the support device including the stake **106** and the hook **108** are releasable from and connectable to each other.

When a person is considering purchasing the light device **102**, the person may wish to open the device package **158** in the retail store so as to more closely inspect the light device **102**. In order to avoid creation of tension between the test button **162** and the insert **174** which may result in damage to the wiring system of the device packaging **158**, one or more of the wires extending between the test button **162** and the insert **174** may be folded back on itself and the folded portion potted with glue or resin. This creates a strain relief point.

In order to reduce the likelihood that insufficient power is available for a user to test the light device by pressing the test button **162**, one or more additional batteries may be included. The or each additional battery may be a rechargeable or non-rechargeable battery and in one arrangement, the additional battery is disposed in parallel or in series with the rechargeable battery **170**.

A further variation to the light device **102** is shown in FIG. **20**. In this variation, the light device **102** may be connected to a wind indicating device **210**, for example of the type described in co-pending U.S. patent application Ser. No. 11/303,247 by the present applicant, the contents of which are hereby incorporated by reference.

The wind indicating device **210** includes several chime members **212**, a striker **214**, and a pendulum **216** which in this example is provided with a light emitting device **218**. The light emitting device **218** may be provided with power through the support elements **126** in a similar way to the variation shown in FIG. **19**.

In the claims which follow and in the preceding description of the invention, except where the context requires otherwise due to express language or necessary implication, the word “comprise” or variations such as “comprises” or “comprising” is used in an inclusive sense, i.e. to specify the presence of the stated features but not to preclude the presence or addition of further features in various embodiments of the invention.

Modifications and variations as would be apparent to a skilled addressee are deemed to be within the scope of the present invention.

The claims defining the invention are as follows:

1. A light device comprising:

- a first portion configured so as to partially define a housing, the first portion being arranged so as to at least partially pass light therethrough and the first portion including first electrical contacts and a first locking device;
- at least one light emitting element disposed in the first portion and being electrically connected to the first electrical contacts;
- a second portion including a battery compartment, second electrical contacts arranged so as to be in electrical connection with at least one battery disposed in the battery compartment during use, and a second locking device engageable with the first locking device so as to releasibly fix the second portion to the first portion during use and thereby close the housing;
- a solar power converting device attached to the second portion, and arranged to convert solar power to electrical power, and
- said at least one battery electrically connected to said solar converting device, and arranged to store electrical power provided by the solar power converting device;

wherein, during use, when the first and second locking devices are engaged with each other, the first electrical contacts electrically connect with the second electrical contacts so as to thereby electrically connect with at least one battery disposed in the battery compartment during use to the at least one light emitting element.

2. A light device comprising:

- a first portion configured so as to partially define a housing, the first portion being arranged so as to at least partially pass light therethrough and the first portion including first electrical contacts and a first locking device;
- at least one light emitting element disposed in the first portion and being electrically connected to the first electrical contacts;
- a second portion including a battery compartment, second electrical contacts arranged so as to be in electrical connection with at least one battery disposed in the battery compartment during use, and a second locking device engageable with the first locking device so as to releasibly fix the second portion to the first portion during use and thereby close the housing;
- the first portion including at least one translucent panel and the at least one light emitting element being disposed in the first portion such that light from the at least one light emitting element is diffused by the at least one translucent panel;
- a solar power converting device attached to the second portion, and arranged to convert solar power to electrical power, and
- said at least one battery electrically connected to said solar converting device, and arranged to store electrical power provided by the solar power converting device;
- wherein, during use, when the first and second locking devices are engaged with each other, the first electrical contacts electrically connect with the second electrical contacts so as to thereby electrically connect with at least one battery disposed in the battery compartment during use to the at least one light emitting element.

3. The light device as claimed in claim **2**, wherein each first electrical contact includes a raised portion arranged so as to encourage good electrical contact with at least one of the second electrical contacts during use.

4. The light device as claimed in claim **2**, wherein each second electrical contact is formed of resilient material so as to encourage good electrical contact with one of the first electrical contacts during use.

5. The light device as claimed in claim **2**, wherein the first portion is a base portion of the light device, and the second portion is a lid portion of the light device.

6. The light device as claimed in claim **2**, wherein the first portion includes at least one transparent panel and a simulated candle having the at least one light emitting element disposed in the simulated candle, the simulated candle being arranged so as to diffuse light passing therethrough from the at least one light emitting element.

7. The light device as claimed in claim **2**, wherein the at least one translucent panel is formed of frosted glass.

8. The light device as claimed in claim **2**, wherein the light device further comprises a control unit for causing the at least one light emitting element to emit flickering light.